

- [11] Freudenthal, H., 'Geometry Between the Devil and the Deep Sea', *Educational Studies in Mathematics* 3 (1971), 413-435.
- [12] Freudenthal, H., 'Didaktische Phänomenologie mathematischer Grundbegriffe', *Der Mathematikunterricht* 23/3 (1977), 46-73.
- [12a] Fricke, A. and Besuden, H., *Mathematik, Elemente einer Didaktik und Methodik*, Klett, Stuttgart, 1970.
- [13] Geometry Conference Recommendations, *Educational Studies in Mathematics* 3 (1971), 286-287.
- [14] Holland, G., 'Strategien zur Bildung geometrischer Begriffe', in *Beiträge zum Mathematikunterricht 1975*, Schroedel, Hannover, 1975.
- [15] IOWO-Team, 'Five Years IOWO. On H. Freudenthal's Retirement from the Directorship of IOWO', *Educational Studies in Mathematics* 7 (1976), 183-367.
- [16] Kempinsky, H., *Lebensvolle Raumlehre*, Leipzig, 1926, 10th rev. and augm. edition, Verlag der Dürschschen Buchhandlung, Berlin-Born-Brammenburg/Obb., 1952.
- [17] Lorenzen, P., 'Das Begründungsproblem der Geometrie als Wissenschaft der räumlichen Ordnung', *Philosophia Naturalis* 6 (1961), 415-431. Reprinted in P. Lorenzen, *Methodisches Denken*, Suhrkamp, Frankfurt am Main, 1968.
- [18] Moulton, J. P., 'Some Geometry Experiences for Elementary School Children', *Arithm. Teacher* 21 (1974), 114-116.
- [19] Müller, G. and Wittmann, E., *Der Mathematikunterricht in der Primarstufe*, Vieweg, Braunschweig, 1977.
- [19a] Piaget, J., *Introduction à l'Épistémologie Gênéralique*, Tome 1, *La Pensée Mathématique*, Presses Universitaires de France, Paris, 1950.
- [20] Schreiber, A., 'Die operative Genese der Geometrie nach Hugo Dingler und ihre Bedeutung für den Mathematikunterricht', *Der Mathematikunterricht* 24/5 (1978), 7-24.
- [21] Schreiber, A., 'Idealisierungsprozesse - Ihr logisches Verständnis und ihre didaktische Funktion', forthcoming in *Lehrn. f. Mathematik-Didaktik*.
- [21a] Schreiber, A., 'Universelle Ideen im Mathematischen Denken - Forschungsgegenstand der Fachdidaktik', forthcoming in *Mathematisches Didakt.*
- [22] Schuster, S., 'On the Teaching of Geometry. A Postscript', *Educational Studies in Mathematics* 4 (1971), 76-86.
- [23] Stühmann, H.-J. and Wessels, B., *Lehrerhandbuch für den technischen Werkunterricht*, vol. 1, 2nd edition, Beltz, Weinheim, 1972.
- [24] Whitehead, A. N., 'The Mathematical Curriculum', in *The Aims of Education and Other Essays*, New York and London, 1929.
- [25] Winter, H., 'Vorstellungen zur Entwicklung von Curricula für den Mathematikunterricht der Gesamtschule', in *Beiträge zum Lernzielproblem*, Bonn, Ratingen, 1972.
- [26] Winter, H., 'Die Erschließung der Umwelt im Mathematikunterricht der Gesamtschule', *Sachunterricht und Mathematik in der Grundschule* 7 (1976), 337-353.

## THE PRINCIPLE OF OPERATIVE CONCEPT FORMATION IN GEOMETRY TEACHING

In recent discussions the logical (deductive) structure of geometry as a predominant guiding principle for geometry teaching has become more and more questioned (see [21]). Instead more emphasis is placed on informal aspects of concept formation, not least by regarding geometry "as an important means of understanding and organizing spatial phenomena" ([13, p. 286]). Such considerations have given rise to recommendations that geometry should be taught at the primary level [1]. But above all, the most significant demands appear to be for practical activities with concrete forms, and the exploration of the primordial relation between geometry and reality (cf. [11], in particular the list of 'haphazard questions' on p. 418f; and [9]). In our studies on geometric concept formation [3, 4, 20] we proposed that these demands could be met by using a didactical principle which we call the principle of operative concept formation (POCF).

### 1. OPERATIVE GENESIS OF GEOMETRICAL CONCEPTS

One of the most important problems in learning geometry is that of acquiring geometrical concepts. In traditional instruction there are mainly three ways of introducing such concepts:

- (a) by definition (language),
- (b) by giving examples (intuition),
- (c) by drawing (construction).

(For that see [14].)

Let us take, for example, the concept of the straight line.

Concerning (a): Being a primitive concept, 'straight line' is usually not defined at all. One could define it by means of intersections of planes, but this leaves the task of explicating what 'plane' means. Even if a concept remains undefined, there are still certain facts about it that can be formulated as axioms; e.g., two straight lines which lie in one plane are either parallel or intersect in one, and only one point; or every straight line is determined by two of its points.

Concerning (b): One could ask: Where do straight lines occur? There are many suitable phenomena such as the edge of a table, axes of rotation, rays of light, etc.

Concerning (c): The standard method is producing, or rather reproducing, straight lines with a ruler. Other possibilities are folding a sheet of paper or stretching a thread.

Of course, these three ways of introducing concepts are all indispensable to any method of teaching geometry. On closer inspection, however, there appear certain epistemological and pedagogical problems. Language, intuition, and construction are widely used in an essentially empiricist manner, that is, instruction is based upon the opinion that geometrical concepts are mainly derived from things in the world around us, by some sort of abstraction. However, one should not forget the fact that most of those real forms representing geometrical ideas do not arise from nature, but are artificial, made by man, such as rulers, edges, stretched threads, folded sheets of paper, wheels, rollers, boards, bricks, screws, . . . . Therefore the genesis of concepts like 'straight line', 'circle', 'cylinder', 'plane', 'orthogonal', 'parallel' is not complete if based on mere contemplation or reproduction of such forms. In fact, these concepts are not found as such in nature, but exist first as ideas in man, who carries them into the physical world for his own purposes. This origin is, in our opinion, an essential part of geometric concepts. (Cf. [7] and [21].)

This requires a method of evolving concepts which complements the three ways mentioned above. It will not simply be added to them as a fourth way but will be used in each of them. We call it the *principle of operative concept formation* (POCF), which reads as follows:

*Geometrical concepts are formed operatively, that is, starting from given purposes, norms are developed to generate forms which fulfil these purposes. The norms, mostly homogeneity postulates, are associated with rules for their realization by exhaustion, thus establishing an actual basis for the concepts attached to them.*

We want to explain this principle with the following scheme (Figure 1), taking as an example a possible formation of the concept 'Quader' (rectangular solid).

To build a wall bricks are needed that ensure solid, gapless construction. The bricks should not be too big, or too heavy, so that the bricklayers can handle them without too much effort. The tessellation of the wall must not be determined by the position of one brick, but must be variable. Furthermore, all sides of the bricks should be parallel or orthogonal to the direction of gravity.

An *analysis* of these *purposes* leads to the following *geometric function* of the brick: it should fit copies of itself, it should fit into the gravitational field, it should fit into the human hand. Fitting of geometric forms (i.e., (partial) incidence of their surfaces) generally requires three aspects to be considered:

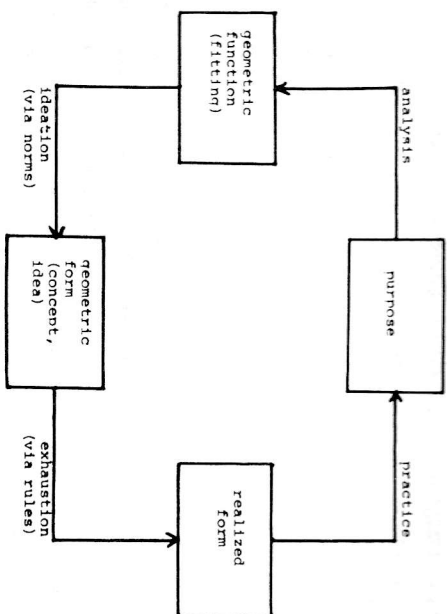

Fig. 1. Scheme of the operative concept formation.

restriction of movableness, optimization (size and proportions of the brick in our example), and measurement (three short edges yield one long one). Only the first aspect is really essential for the purpose of the brick, that is, variable parquetry of walls within the gravitational field.

From these considerations we can derive a *norm* for bricks: A brick must have pairs of parallel plane sides, these pairs being orthogonal to each other. Thus the *concept* of the Quader has been generated by *ideation*, involving, however, the concepts 'plane', 'parallel', and 'orthogonal'. This concept is *exhausted* by the usual brick (*realized form*) up to a certain degree of accuracy which depends on the purpose and use of the brick. This degree of accuracy need not be too high, because many irregularities can be compensated for with mortar.

Thousands of years of *practice* have proved this form of brick to be the most expedient one for the purpose of constructing walls.

Let us now have a closer look at the two arrows 'ideation' and 'exhaustion' in Figure 1.

By *ideation* we mean, roughly speaking, procedures which lead, via norms, to (a system of) concepts (ideas) being used as if those norms held. This means essentially that the ideas are not gathered from reality, but conceived on their own and then carried into it; (for a general discussion of this point see [21]).

As Dingler stressed in [7], norms for geometric forms frequently demand the points of the surface to be indistinguishable. This is equivalent to the postulate that a property attributed to at least one point has to be attributed

to all points (*homogeneity postulate*). There is a close relationship between homogeneity and symmetry (cf. [4]). At the pre-geometrical level, homogeneity affects various phenomena: a drawer can be moved in its bearing; things on tables can be placed everywhere; a wheel rolls without hitching; etc. Homogeneity of surfaces, for example, can be formulated precisely (after Lorenzen [17]) by the following scheme:

$$P|S \wedge P'|S \wedge \mathcal{A}(S, P) \rightarrow \mathcal{A}(S, P')$$

That means: All sentence forms  $\mathcal{A}(S, P)$ , with no free variables other than  $S$  and  $P$ , that are true for the point  $P$  of the surface  $S$ , are also true for every other point  $P'$  of  $S$ . Why, for example, does the surface of a tin can come to be inhomogeneous in the sense of this scheme? Taking for  $\mathcal{A}(S, P)$  the sentence form 'In  $P$  exists one, and only one support plane of  $S'$  regular points of  $S$  fulfilling  $\mathcal{A}(S, P)$ ' can be distinguished from edge points having more than one support plane (Figure 2). Without proof we mention the fact that the only surfaces for which the above scheme holds are the plane, (the surface of) the sphere, and (the surface of) the (infinite) cylinder. Straight line, circle, and helix represent the corresponding homogeneous curves. (For details cf. [4].)

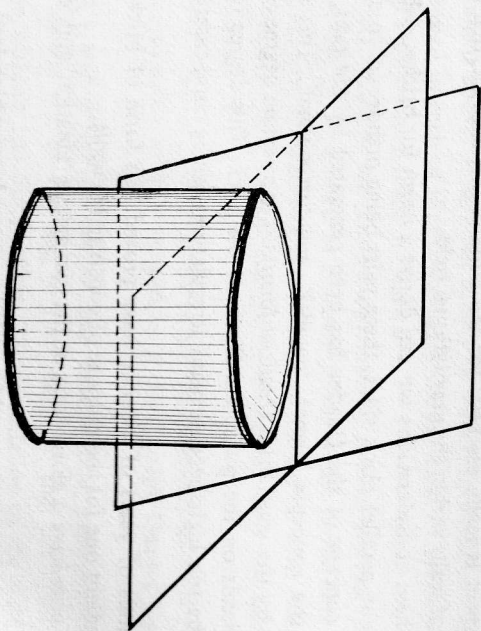

Fig. 2.

As to the arrow called *exhaustion*, procedures are to be considered which, via suitable rules, produce real forms that represent a given geometrical concept. Exhausting a geometric idea essentially means making a series of real forms with increasing degree of accuracy, i.e., which fulfil the given idea (norm) with growing perfection. (The terminology follows [8]; see also [20].)

Simple examples are the realization of a point by sharpening a pencil, or of a straight line by intersecting two planes (e.g., on a cube). Obviously, in both examples planes already embodied are involved. Planes, for their part, can be produced by taking three plates and grinding two of them on each other alternately ('three-plates-method', first systematically applied in industrial production by Maudslay in the beginning of the 19th century). Homogeneity is effected by the grinding; curvature vanishes in consequence to taking *three* plates. Exhaustion never yields a perfect representation of the concept itself; geometrical forms can only approximately be represented by real forms, the degree of accuracy depending on the given purpose. For example, it is unnecessary to sharpen a pencil too much, to straighten the edges of a flower bed with a ruler of precision, or to polish a brick.

The POCF, till now, has dealt with the formation of concepts, involving analyses of purposes, making real forms and their practical use. These operations differ from what is usually understood by Piaget's term 'operation': for an instructive description of this term, particularly its possible role in mathematical education, see Fricke/Besuden [12a; pp. 12 ff]. In short: operations are introverted actions which are organized in so-called groupings, i.e., states of dynamic equilibrium of thinking; their generation and application are understood as causal phenomena as a consequence of man being part of his physical and biological surroundings (cf. the 5th paragraph of the introduction to Piaget [19a]). In distinction from that our concept of operation includes essentially human intentions.

## 2. EXAMPLES FOR THE PRACTICAL USE OF GEOMETRIC FORMS

In searching for concepts which play a fundamental role in geometry we find, among others, the following ones: plane, sphere, cylinder, straight line, circle, helix, symmetry, parallelism, orthogonality, polyhedron, (truncated) cone, polygon, line segment, convexity, rigid body, congruence. All these notions are connected with homogeneity, more so at the beginning of the list than at the end. From this list we will take four examples and study their application and practical use in connection with homogeneity.

*The plane.* Many things used in everyday life, and in engineering, possess plane surfaces. These forms fulfil a great number of purposes, whose analysis brings mainly three functions to light: Neutralizing gravitation, movableness of a solid in its bearing, and forming a common border for two convex areas of space.



Billiard-tables, dining-tables, floors, pavements, roadways, and stairs are plane, and, when positioned in the gravitational field as accurately as possible, objects on them can be put anywhere and be moved in any direction without being affected by gravitational forces.

The function of movableness is essential in the following examples: timber is planed by sawing, walls made of concrete are smoothed down with a plane board, objects with a plane bottom can be slid arbitrarily on plane supports. This movableness is the direct result of homogeneity and therefore can also be found on the sphere and the cylinder (ball-bearing, ball-point pen, piston, revolving-door, corkscrew).

The third function (forming a common border for two convex areas of space) admits only planes, as, for example, walls of rooms, sides of boxes to be piled on top of each other, faces of bricks, or the surface of a mirror. In these cases the geometrical indistinguishability of the two sides of the surface is needed. As to the mirror, it can be moved arbitrarily in its imaginary bearing (the plane defined by its surface) without distorting the picture. Not only must the two half-spaces determined by this plane be of equal form but also any two corresponding parts of them.

*The truncated cone.* No less important than homogeneity, as illustrated by the form of the plane, are the intended deviations from it. A simple example is the truncated cone which deviates from a finite cylinder by having a bottom and a top of different sizes. This form is given to funnels, waste-paper-baskets (also as truncated pyramids), buckets, handbasins, deceptive packaging, tall chimneys, the screw in mincers, conic gears, flower-pots, bricks in arches. It fulfils the various functions required by these objects.

A large opening facilitates filling and emptying a container. So, water can be poured out of a truncated cone handbasin with less effort and better balance than out of a cylindrical one which has an equally wide opening (Figure 3). This is because a great part of the water lies on the other side of the fulcrum and therefore does not have to be supported; in fact, it even supports the tilting of the handbasin by its weight, and, moreover, the water-level does not rise too fast. Also, one needs less water to fill it up.

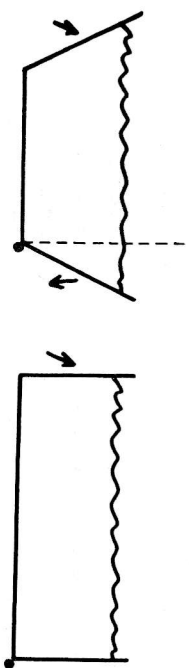

Fig. 3.

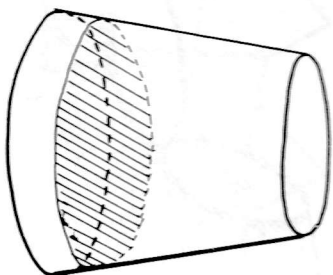

Fig. 4.

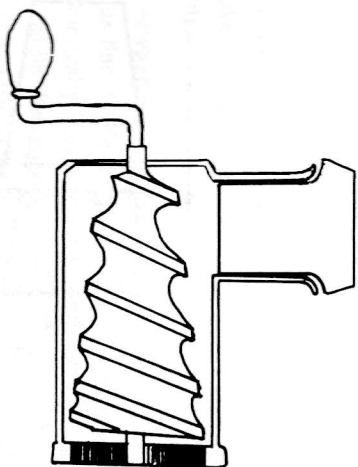

Fig. 5.

The truncated cone also differs from the cylinder in that its volume does not depend proportionally on its height (Figure 4). Therefore deceptive packaging is sometimes given the form of a truncated cone: lifting its inner base produces a relatively greater loss of volume. Moreover this form is very stable when standing. This principle is also used in stabilizing tall buildings or certain tankards. Mincers are provided with screws which gradually become thicker at one end, thus crushing the food that runs through it better (Figure 5). In gearings conic gear wheels are used to transmit rotations to non-parallel axes (Figure 6).

The truncated cone, unlike the cylinder, is not arbitrarily movable in its bearing. This means that within its bearing it can only be moved *away* from the smaller end, and then it no longer coincides with the bearing at all, or at



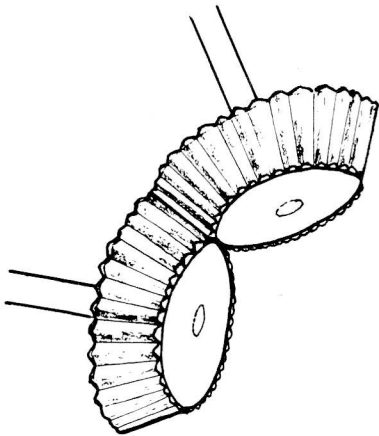

Fig. 6

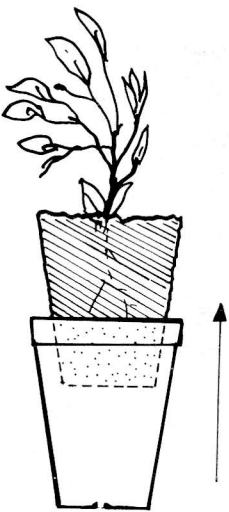

Fig. 7.

most in a line. Thus a flower-pot can be emptied with only one jerk (imagine if flower-pots were cylindrical) (Figure 7). For the construction of arches, bricks are used that have the form of truncated wedges that cannot fall out of the bearings formed for them by surrounding bricks. Shopping carts are equipped with containers and undercarriages shaped as truncated pyramids (wedges) and one movable side so that they can be slid into each other in order to save space (Figure 8).

In some objects several functions of the truncated cone are combined. Drinking cups have large openings and, held in the hand, cannot fall down because of their conic shape. When they are made of plastic, they can be inserted into each other like the shopping carts. Jelly moulds are formed

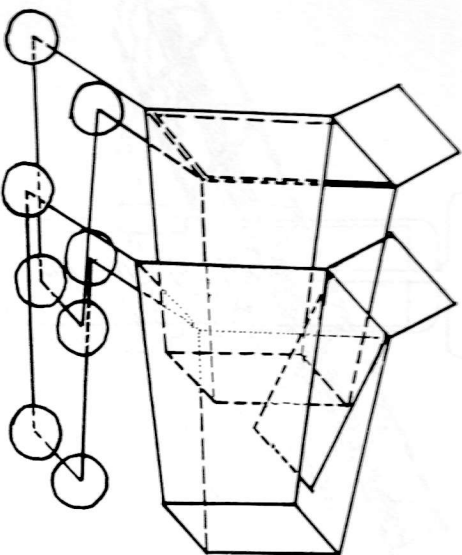

Fig. 8.

like truncated cones: having turned the mould upside down one can easily lift it, thus removing it from the jelly without the jelly losing its shape owing to its conical form.

*The helix.* A somewhat more sophisticated geometrical form is the helix, the only homogeneous line which does not lie in a plane. Its function can only be understood kinematically and consists essentially in moving objects along a given straight line while they rotate around this line (the axis of the helix).

Although the (cylindrical) helix is homogeneous, which means it is freely movable in its bearing, the rotation around its axis is by no means a motion within its bearing, at least if one thinks of the bearing as fixed to the axis. It then functions like a cylinder; for example a drill bit when set on a work-piece does not generate a helix, but a cylindrical hole. However, a rotating helix stays in its bearing, if this bearing does not rotate but is moved along the axis with suitable velocity, for example a nut on a bolt. Hence the helix functions by simultaneously turning and sliding two objects against each other.

A striking example for this is the corkscrew within a frame (Figure 9): it is put on the neck of the bottle, and the helical screw is driven into the cork by turning the handle. The screw moves downwards until it cannot go any further. If one continues turning it in the same direction, the relative movement of the screw against the cork goes on, and the cork is lifted out of the bottle into the frame. If the frame is narrow enough, the cork can be

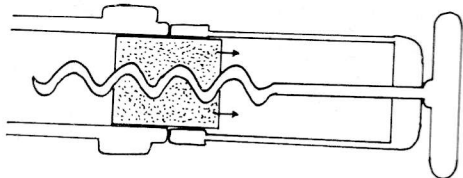

Fig. 9.

removed from it by turning the screw in the other direction. Both in the bottle and in the frame, the cork cannot turn with the screw because of its pressure against its enclosure. During the whole procedure no tractive force need be applied, only rotational force.

It is just this relationship between the rotation carried out and the intended movement along the axis that is used as a functional principle in many practical appliances like the wine-press, the printing-press, the corkscrew, screw tops, and bolts with nuts. In these examples two things, being partial bearings to one another, are moved relative to one another along a helix and thus pressed tightly against each other in the direction of the axis. With the exception of the corkscrew, these helices have a small pitch, and therefore their turns are nearly circles that are orthogonal to the axis, so that only a small amount of the force opposed to the pressure along the axis acts upon the helix, working against the screwing, or loosening the connection.

There are also objects in which a straight motion is transformed into a rotation by a helix, for example, a certain kind of mechanical screw-driver (Figure 10). Of course, their helices must be rather steep.

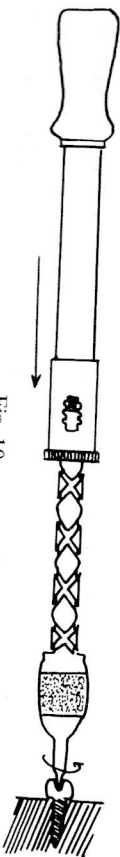

Fig. 10.

All these mechanisms would not work, if the helices were not homogeneous, especially if they did not have a constant radius and a constant pitch.

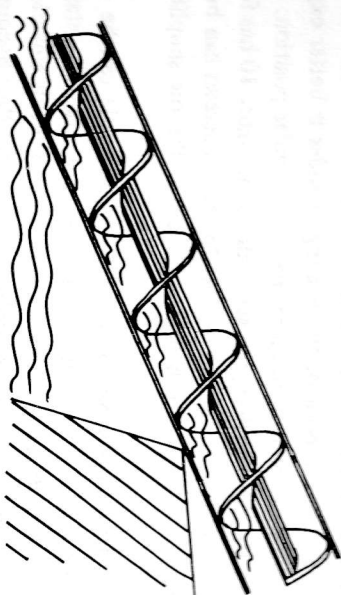

Fig. 11.

A famous application of the forementioned functional principle is the Archimedeian screw which is used as an elevator for water, sand, or grain (Figure 11). It consists of a hollow cylinder and a helical surface, with the same radius, in it. If the cylinder is filled up with water (sand, grain), the water encloses the helical surface like a bearing. If then the tube is tilted and the helix starts turning, gravitation keeps the water in a fixed position and prevents it from participating in the rotation, and the 'bearing' consisting of water is slid out of the cylinder.

In practice the lower end of the Archimedeian screw is dipped into water. Of course, the tube is not completely filled with water by the rotation, but in each turn a small quantity is elevated. Insofar as this 'bearing' is not solid, homogeneity of the helix is not indispensable. Still more imaginary is the bearing of winding staircases or chutes: it consists of the potential traces of persons or things on them. Accordingly, homogeneity needs to be realized to a lesser degree still.

The common purpose underlying these examples is to move things from one place to a higher or lower one within the gravitational field. The helix is not in the form of a line but of a two-dimensional surface which can be conceived as the trace of a curve segment which is uniformly screwed along a straight line. The helical surface is not a homogeneous form and therefore cannot be moved freely in its bearing (two-dimensionally), but at most along a helical line (one-dimensionally).

Hence corkscrews need not necessarily be helices but can also be made as helical surfaces, because these, too, can be screwed into a cork. Yet, they are of inferior quality as they leave a nearly cylindrical hole in the middle of the cork.

Sometimes, several helical lines or surfaces are wound into each other so that the surface or the interior of the bearing cylinder is better exploited and the screwing can be started from more than one angular position. Screw tops can have up to six short helices; the screw-driver in Figure 10 has four helices, two in each orientation; for actual use, Archimedean screws can be fitted out with two, three, or even more helical surfaces (unlike the simplified version in Figure 11).

Concerning the construction of a helix, its principle can be understood best in the example of the (winding) staircase. Essentially, a staircase is an inclined plane (with steps) for surmounting differences in elevation. For the sake of saving room it is wrapped around an axis and thus becomes a helical surface, while its handrail becomes a helical line. In geometrical terms this comes to the same thing as wrapping a triangle around a cylinder.

This procedure results in a simple method for determining the length of a finite piece of a helix without calculus immediately. Textbooks of analysis usually treat this question by evaluating the integral

$$\int_0^\alpha \|f'(t)\| dt,$$

where  $f(t) = (r \cos t, r \sin t, pt/2\pi)$  is a parametric representation of the helix in the interval  $0 \leq t \leq \alpha$ . A more elementary and adequate way is derived from the method of construction described above and only uses the Pythagorean theorem and similarity arguments (Figure 12). Let  $r$  be the radius of the cylinder,  $p$  the pitch of the helix,  $\alpha$  the rotational angle, then  $L_{2\pi}^2 = p^2 + (2\pi r)^2$ , and  $L_{2\pi} : L_\alpha = 2\pi r : \alpha r$ , whence  $L_\alpha = (\alpha/2\pi) \sqrt{(2\pi r)^2 + p^2}$ .

Usually the pitch is small compared with the length of one turn. Therefore variations of the pitch yield only small variations of the radius. This property proves essential for the way springs and spring-balances work. A tractive or a pressing force on a helical spring along the axis causes a variation of the pitch, which becomes smaller the more turns there are on the helix. This, in turn, generally causes a variation of the radius which is so small that the spring is deformed elastically and does not reach its limit of elasticity. These arguments still hold, when the spring is not a homogeneous helix but a conical one, or one with rectangular turns as in the magazine of a pistol (Figure 13).

*The hexagon (bolt nut).* The series of examples we have presented so far does not contain in each case a thorough analysis of the transition from purpose and geometric function to the geometric form; such details would have expanded our considerations unduly. Yet we have already given a more detailed analysis of the brick in Section 1 and will give one for the football in Section 4. Now

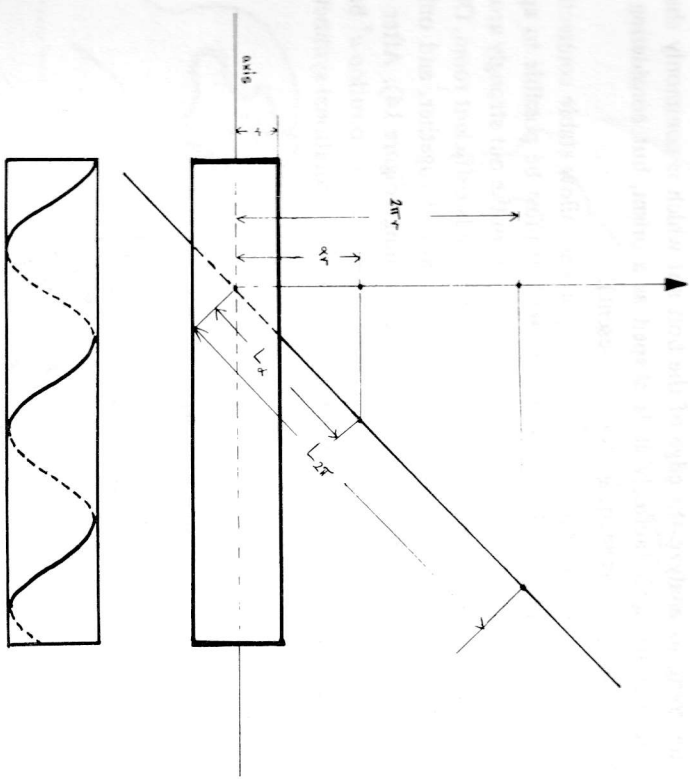

Fig. 12.

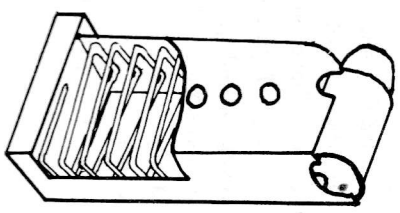

Fig. 13.



we are going to analyze the edge of the bolt nut which is commonly shaped as a regular hexagon (actually it is shaped as a prism, but considering the problem in the plane is adequate for the present).

The edge of the nut should, to fulfil its purpose, allow stable connections with a long and, in general, rigid lever (wrench). It must be possible to apply and to loosen the wrench easily, and to use it to turn the nut strongly around a fixed axis. For this motion, the long lever arm needs sufficient room. Often this room is occupied by the elements to be screwed together, and only a relatively small angle of, say  $\alpha^\circ$ , remains for turning (Figure 14). After one turn of about  $\alpha^\circ$ , the wrench must be applied to the nut in a position  $\alpha^\circ$  backwards for the next turn. Consequently the nut must have rotational symmetries of at least order  $360/\alpha$ .

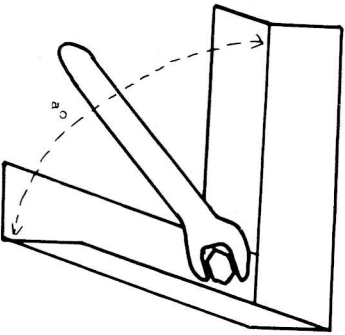

Fig. 14.

Its stability is mainly effected by that part which belongs to the maximal circle which can be inscribed into the form of the nut, whereas the projecting parts contribute less. For that, it would be economic to provide the nut with a circular, and hence homogeneous, edge (Figure 15). Unfortunately this would mean that a wrench fitting this edge would (geometrically) be freely movable and would be connected with the nut only by adhesive friction.

The wrench should confine a large angle at the nut in order to avoid slipping of its jaws. Furthermore, the contact edges should be long and perpendicular to the direction of the turning force (Figure 16). The forms of the wrench and the nut must fit together: one is the bearing of the other.

One should be able to slide the wrench onto the nut. In the plane, motions which can freely be carried out in a bearing must be straight or circular. From this the two alternatives in Figure 17 result as the only possible ones. In both

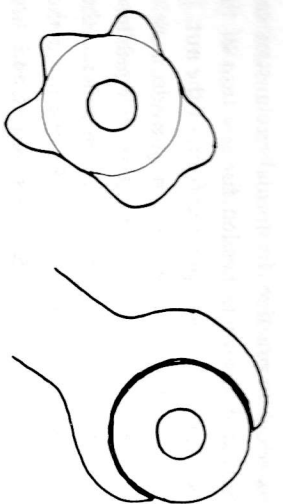

Fig. 15.

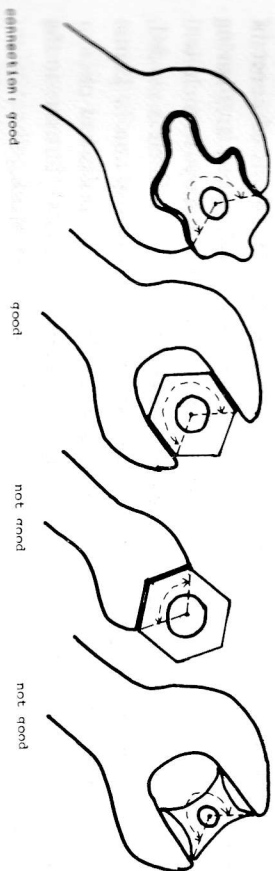

Fig. 16.

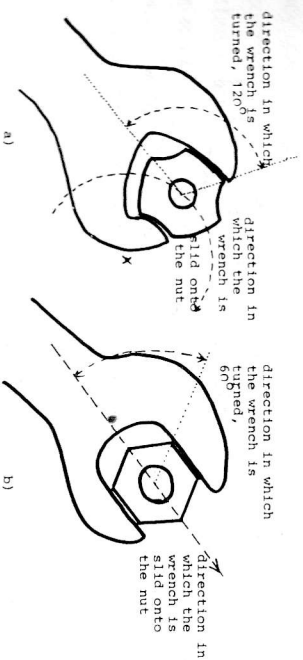

Fig. 17.

cases those parts of the edge along which the wrench can be slid must be parallel lines. In case (a) this would mean: opposite arcs belong to concentric circles, and, consequently, convexity is lost,  $n$ -fold symmetry requires the edge to consist of  $2n$  pieces, and the wrench is liable to slip. Therefore the parts of the edge are made as pairwise parallel straight line segments (case (b)). The whole figure is a regular polygon whose number of vertices is even and not too large, perhaps 4, 6, or 8.

All three forms occur in practice. In normal circumstances the side of the octagon is too short and the angle needed for one turn of the quadrangle is too large. So the hexagon is the most popular form of the nut.

The form in which water taps are frequently made is neither a hexagon, nor an even-numbered polygon at all, but it is an equilateral triangle with sides curved inwards. The reason for this is that in general, the taps are easily accessible and therefore can be made larger. Furthermore they need not be tightened too much. So no particular lever is required, and three fingers of the human hand suffice.

In [18] a remarkable species of 'bolt nut' is described thus: in Philadelphia, U.S.A., fire hydrants are protected from misuse by the heads of the shafts being shaped as Reuleaux triangles (Figure 18). This is a form of constant width, as it is an equilateral triangle whose sides are replaced by arcs having centres in the respectively opposite vertices. So an ordinary wrench will slip around it, even if it has suitable width, and a special wrench is needed. The Reuleaux triangles can be interpreted as forms like the one in Figure 17(a) with vanishing radius of the smaller circle. If those shafts had circular heads, ordinary wrenches could also not be applied, of course, but due to the homogeneity of the circle even special wrenches would not work.



Fig. 18.

### 3. THE DIDACTICAL FUNCTIONS OF THE POCF

We shall now describe what the POCF can do for geometry teaching, by giving some comments on several of its didactical functions which we consider to be relevant. It will be shown that the POCF proves to be not only the essence of an epistemological understanding of geometry but also an efficient didactical principle.

*Opening up the real world.* Ever since geometry was first reflected upon, it has tended, in its foundations and in its teaching, to detach itself from reality.

Of course, there have always been attempts by didacticians to compensate for this tendency. We only mention here Kempinsky [16], Freudenthal [11], and Winter [26].

According to the customary view the connection between theories and reality is such that the theories reflect certain sections of reality ('Widerspiegelung') and therefore can be interpreted as models for it. But for many theories, especially for geometry, this kind of connection is not sufficient, as it is only possible on a more advanced level of theory formation, namely after the fundamental concepts have been constituted. In geometry this is done according to the POCF, which means that concept formation is linked with the practical operations by which the real world is shaped ('Ergreifung der Wirklichkeit'). These operations, and not reproductive procedures, guarantee that our geometrical ideas match with reality. Both ways of connecting theories and reality are component parts of what we call 'opening up the real world' ('Umwelterschließung'). Thus opening up the real world is an essential part of concept formation and not merely a type of motivation for the students.

Our examples of the practical use of geometrical forms comprise typical phenomena that should be dealt with in geometry lessons in which an adequate understanding of geometric structures in the real world is aimed at. In particular, this involves considering the purposes of everyday objects having more or less technical features. Everyday objects are to be preferred because they are more accessible, their purposes can be identified more easily, and their expediency can be controlled more definitely. In order to understand how (these geometrical forms work one has to place the emphasis on kinematical aspects, thus overcoming the poor conceptions acquired by a mere description of shapes as can be found in many textbooks. Furthermore, real space is three-dimensional. Certainly a lot of problems can be reduced to two dimensions, but many important geometrical ideas can only be grasped if their three-dimensional character is heeded.

*Central ideas.* In pedagogy there is the old and plausible, but nevertheless often neglected, advice that education should not focus on subordinate matters, but on the central ideas of a discipline (recommended for example by Whitehead [24] and Bruner [6]: see also Schreiber [21a]). The central ideas of a theory should not be thought of as its primitive (basic) notions, but rather they are the key concepts which bring to light fundamental results and specific patterns of thinking at a more advanced stage of the theory. From our operative point of view the following ideas turn out to be central: exhaustion, homogeneity, and fitting of forms.

The idea of *exhaustion*, given in its special form for operative geometry in

Section 1, is to be seen as a collective notion for any kind of approximating procedure, and at the same time it is thereby the theoretical forerunner of mathematical approximation. In practice, as well as in teaching, exhaustion plays a fundamental role not only in making real forms, as pointed out in Section 1, but also in measurement.

An idea more specific to geometry is *homogeneity*. By dealing practically with geometric forms the students recognize that homogeneity, and the intended deviations from it, are indispensable for their functioning. In the preceding sections we have already presented several examples of homogeneous forms. Besides the truncated cone there are various kinds of deviations, e.g., the staircase (its basic form in the inclined plane; the deviation consists in the steps), the cogwheel (circle; cogs), the shaving-mirror (plane; curvature), the barrel of a pistol (cylinder; a helical line on it), the bowling ball (ball; holes), etc.

One central idea which is peculiar to geometry we call the *fitting of forms*, being one more constituent part of the POCF (cf. Figure 1). Freudenthal [11] has pointed out the relevance of this idea. Any geometric function seems to be such a fitting of forms.

As we pointed out in Section 1, there are three aspects to be considered: restriction of movableness, optimization, and measurement.

The most characteristic and obvious aspect is the *restriction of movableness*, possibly even immovableness. A typical example is the brick in a wall; others are: a key in its hole, a train on the rails, a wrench on a nut, and any movableness of a form within its bearing for which we have noted some examples in Section 2.

*Optimization* is a somewhat more complicated aspect: although there are operations research methods for solving a great number of optimization problems where the objective function and the constraints are known, a geometric form is determined less cogently by optimization arguments, as the choice of the objective functions and the relevance of the constraints are influenced by subjective views. Along which line is a road laid out in a terrain? Besides the geometrical aspects others, especially economic ones, have to be taken into account, and so roads are often not straight. The size of bricks or space-saving arrangements of things are further examples of geometrical optimization. Also outside geometry optimization has an obviously operative sense. Clearly, for many problems, even purely geometrical ones, optimization requires operations going beyond geometry, e.g., numerical, due to the measuring process involved.

The idea of *measurement* is essentially geometrical, but it also comprises non-geometrical operations, namely obtaining and processing numerical measuring data. Originally measuring is a kind of geometrical fitting: in order

to find out whether a wardrobe passes through a door one can try with the wardrobe itself; one could also take a piece of rope or a stick, apply it successively to the door and to the wardrobe, put a mark on it both times, and compare the marks; one could even use measuring rods and compare the lengths entirely numerically.

These three possibilities represent three levels of modelling, the last one going beyond geometry by using numbers. Numbers have to be employed because often a direct comparison of real objects is rather difficult or even impossible. Besides, there are situations where data have to be determined for purposes other than the fitting of forms. For example, in order to determine the required quantity of goods (paint, fertilizer, working time, etc.) one has to know the area of the corresponding surface.

Often measured values are the basis for calculating further quantities which can hardly be measured directly, e.g., the length of an inaccessible line segment by geodesic methods, the area of a rectangle with the formula  $A = p \cdot q$ , the half-life period of a substance with known law of decay.

The correspondence of length and number allows numbers to be treated like geometrical ideas. In many problems of a geometric nature such numbers, whether measured directly, calculated, or given otherwise, can be considered as norms, thus being applied to real situations. On the scale of a measuring rod the mark belonging to the number is discriminated, and at the same time the corresponding segment is copied in some given material.

It is essential for an understanding of measurement to elaborate the assumptions which are made in producing measuring rods. The main problem lies in generating an equidistant scale on a rod and keeping it constant. This can be achieved by fixing a unit segment, bisecting it as far as necessary, and copying it repeatedly, the fineness of the marks depending on the required degree of accuracy. Any of these operations presupposes the *rigid body*, and also the rod itself has to be rigid. The idea of the geometrically rigid body is developed by rules for its (stepwise) realization [4]. We think that an intuitive grasp of operating with rigid bodies is the natural grounding for the idea of *congruence* with all its properties, e.g., those of an equivalence relation.

Congruence itself is involved in the fitting of two forms, insofar as the two contact surfaces are congruent and both forms are situated on different sides. The concept of congruence is also needed for a mathematical treatment of fitting. Yet, in practice, the fitting of forms could not be achieved with absolutely rigid bodies, but rather one must be able to grind, cut, saw, solidify, stick, bolt, or tie together things which one assumes to be rigid afterwards. (Also cf. [12].)



*Learning goals.* We have already stressed that opening up the real world is an essential part of concept formation. This does not mean that reality is a mere vehicle for acquiring geometrical concepts. On the contrary, opening up the real world should be a teaching aim in its own right to which concept formation has to be subordinated. This leads to the following general learning goal for geometry:

*Geometry teaching shall enable the students to structure the real space and to explore the utilization of this structure.*

It is mainly the first half of this postulate which has been discussed in publications concerning geometry teaching. The goal corresponds to our POCF and is furthered by it. That is made evident by the following specification of partial goals:

- (a) *see through geometric forms and visualize them* (Archimedean screw, Wankel engine, a landscape with the help of a map, etc.),
- (b) *recognize and describe the purpose and expediency of geometric forms* (the hexagonal edge of a bolt nut, the paraboloid surface of a burning mirror, the spherical form of a container for liquid gas under overpressure, etc.),
- (c) *make and model geometric forms* by means of three-dimensional embodiment, operating on a drawing-plane, language, numbers, analytic or algebraic formulae, axiomatic description (constructing with a construction set, functional models of gear transmissions, visual models of solids, simulating the furnishing of a room with small-scale pieces of paper on a floor plan, any kind of constructive drawing, verbalizing and formalizing the properties of a geometrical form, etc.),
- (d) *solve geometric and non-geometric problems geometrically* (the polyhedral structure of a football, linear optimization, Engel's probability abacus, etc.),
- (e) *build up a system of geometric notions* (geometry of the circle attached to transmissions, calculation of volume in relation to deceptive packaging, spatial congruence transformation attached to the helix, etc.),
- (f) *meet with aesthetic aspects* (proportions, viewing and making ornaments, the design of objects used in everyday life, etc.).

Some special reflections on these goals can be found, among others, in [5], [22], and [10] (concerning (a), (d), and (f) respectively).

Of course, in geometry teaching, too, other educational aims have to be pursued as well – social, affective, and cognitive ones. But since they are not specific to it we do not discuss them here. The goals of our catalogue are related to the POCF more or less closely.

In the above formulations the concept 'form' is meant in a slightly wider sense than usual, comprising also more complex function units, like four landmarks determining a field, the lock of a door together with its key, or a clockwork mechanism, etc.

A special type of forms are those arising in nature, like the hexagonal form of the cells of the bee, the upright growth of a tree or the spherical surface of a soap-bubble. Insofar as they are relevant parts of the world around us, the teacher should take them into account in teaching. However, from the operative standpoint they should be treated with reserve, since they are not made intentionally by man in order to fulfil purposes, but they are a result of processes obeying natural laws.

Under the influence of the POCF a concept can never be evolved in isolation. The formation of a concept always affects the formation of neighbouring concepts, thus building a local system. The students have to be made conscious of this process, and they must extend it to building a global system. This entails developing a terminology (definitions), acquiring factual knowledge (propositions, examples), and providing algorithms (for realizations, constructions, measurement).

*Organization.* From our discussion of didactical functions of the POCF up to now several aspects have emerged which may serve the organization of geometry teaching. There are at least three dimensions, where this organization takes place: local, and global structure of contents, and integration of subjects. Most of the examples introduced in this paper are of a local nature. We have already indicated that locally forming a system of concepts is guided by the POCF.

As to the global organization, there can be distinguished three stages in a complete genesis of geometry, following the POCF: firstly, the students become aware of situations and phenomena involving geometric forms in the world around them. They discuss the origins and the purposes of these forms, make (models of) them and handle them consciously. Secondly, the concepts are formed in a more explicit way by analyzing the corresponding geometrical functions. Finally, the system of concepts is ordered formally and given an axiomatic frame. This allows one to prove known facts in a deductive manner. This heuristic sequence of stages corresponds roughly to the cognitive development of children.

The POCF brings about close connections with the rest of mathematics, to handicrafts, technics, physics, and art. The extent to which the integration of geometry with these subjects is carried out depends on additional pedagogical assumptions. In any case geometry is not a part of handicrafts, technics, or physics.

#### 4. HOW TO USE THE POCF IN THE CLASSROOM

We now describe a series of lessons held in 1978 and hope to show how the POCF can be used in the classroom practically. One will realize that the POCF is applied in a slightly modified manner. So, beforehand, we give some explanatory remarks.

For the formation of a concept it is usually not enough to run through the scheme in Figure 1 only once. Different forms can be derived from the same purpose, the form that is the most suitable is found by using all of them practically for the intended purpose. Conversely, different purposes may lead to the same form. Finally, applying our scheme to one concept mostly entails applying it to a whole conceptual context.

A rigorous application of the POCF would presuppose that students be confronted with genuine situations in which a problem involving constructing something exists, that can only be solved by evolving appropriate geometrical concepts (e.g., making furniture, building a bungalow [15; pp. 239–257], constructing a swimming-pool, repairing a watch, land-surveying, etc.). In school, however, most situations are not genuine but contrived ones. In any case a suitable treatment often cannot be achieved because of lack of time, material, and skill.

Real exhaustion, therefore, has to be discussed verbally and replaced by constructing simplified models with already geometrized material, for instance a functional model of a wind-screen wiper with premanufactured elements [23], the surface of a cube with pasteboard, or geometrical drawing on plane paper.

Children usually are well acquainted with many things in their environment which possess geometric forms such as table-tops, marbles, parallel rails, etc. For students it would not be very convincing and for teaching pedagogically not very economic, if the application of the POCF to such forms consisted in inventing them without making use of what the students already know from experience, that is, those forms have to be *reconstructed by an analysis of the purposes* that arise in practical situations.

One more aspect should be taken into account: there is no geometry teaching, whether based on the POCF or not, which is purely 'operative', that means

where each activity directly concerns purpose, making, or practical use of a geometric concept. There are always phases where a system of geometric notions is built up or the efficiency of such a system is made use of in constructions or argumentations, while the POCF is effective only from the background.

But we think the POCF should underlie any geometry teaching and, besides, cultivating the students' *operatively* geometric thinking will be a long process which cannot be rushed. So any teacher who ever tries an accentuated application of the POCF in his (her) geometry lessons must be aware of initial difficulties arising from the students not being used to considering purposes etc.

We are going to present as a hopefully instructive example a sequence of lessons based on the POCF. We call it *geometry of the football*. It deals with the polyhedral structure of the leather football used nowadays. Starting from its *purpose* as an implement for football (soccer) games we deduce several essential features: it should be as good a sphere as possible, it should be elastic and light, and it should be robust. Therefore it has an inner-tyre filled with air and an outer cover made of leather. In the lessons the geometric structure of this cover is discussed. To do so, the purpose resulting from the game and its rules must be introduced into geometry. We must ask about the *geometric function* of the form. Which form is a good sphere and at the same time can be made of (elastic, light, and) robust material? The problem is solved by the *idea* of the Archimedean solid: its surface consists of regular polygonal pieces (of leather) sewn together, each vertex having the same arrangement of polygons around it, i.e., having the same star; the solid thus having a high degree of *homogeneity* and a large symmetry group (Figure 19). The truncated icosahedron with 32 faces and star (5 6 6) proves to be most advantageous. This idea (concept) is realized according to the following rule: cut out 12 regular pentagons and 30 regular hexagons, all 32 polygons with the same edge length, and fit them together so that one pentagon and two hexagons meet in each vertex. In *practice*, i.e., in innumerable football games, this form has proven good.

A great part of the course consists of the transition from 'geometric function' to 'concept' (cf. Figure 1), however, not detached from problems of the

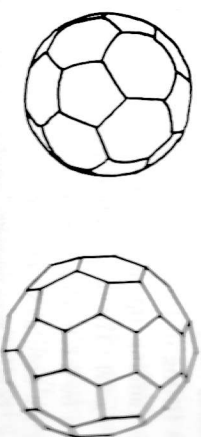

Fig. 19.

world around us, but embedded in such ones; the analysis of the purpose, the making and the use of the concrete object still being essential parts of concept formation.

In realizing Archimedean solids the central idea of *exhaustion* is not so significant, as the concept of Archimedean solid is founded on basic concepts like 'plane', 'line segment', 'angle', 'sphere', 'polygon', 'regular polygon', in whose formation exhaustion has already taken place. But the students come to know the importance of accuracy, when they try to construct solids out of polygons with deviations from regularity or intended edge lengths. Whereas on plane drawings with stencils such deviations can easily be compensated, they are much more difficult to deal with when fitting faces of solids.

Moreover, the idea of exhaustion appears in its mathematized apparel of *approximation* of the sphere by polyhedra. This is an example of *discrete mathematics*, where there is no steady improvement towards an ideal form. In everyday life (more than one could suppose from the contents of school mathematics) there are a lot of problems which cannot be treated with methods based on continuity but which demand special strategies.

We think the course can contribute to the general *learning goal* for geometry which we formulated in Section 3. On closer inspection, however, one can see that the course could satisfy not only any of the six partial goals which are specific to geometry, but also more general goals for mathematics teaching which are discussed for example in [25].

Extensions to the series could be groups, particularly symmetry groups; topological considerations, like the Euler characteristic; trigonometry, e.g., calculation of the solid angles; or a more intensive treatment of the Archimedean solids, like establishing more relationships between them, discussing the two versions of (3 4 4 4), or dealing with the dual solids.

The series was held in the 9th form of a German Hauptschule and consisted of 5 lessons (7 or 8 lessons would have been better). The course ended with a test which the students, on the whole, passed satisfactorily. We will not give an exact record, but rather an improved version, i.e., how we might do it the next time. We think this series would be suitable for use from the 6th grade upwards, as it requires only few prerequisites: some elementary geometric experience (like the fitting of forms) and acquaintance with polygons (perhaps regular) and angles (adding up angles, in particular those of a triangle or perhaps of any polygon). The intellectual level is not too demanding, but the content may even be interesting to grown-up students.

In the classroom we used as *working material*: paper, scissors, glue, pencils, stencils of polygons, rulers, protractors, pocket calculators, sheets with definitions or results, printings of all Archimedean tessellations (Figure 20),

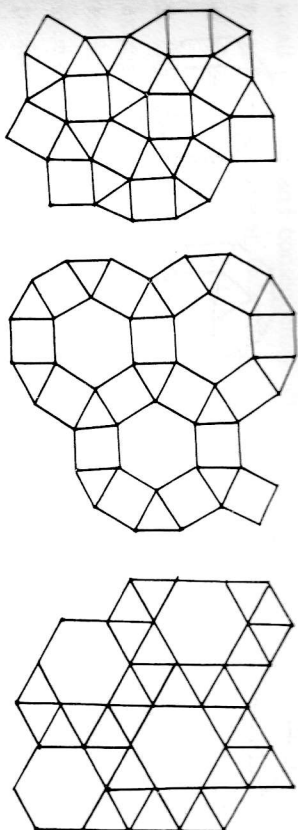

Fig. 20. Examples of plane Archimedean tessellations.

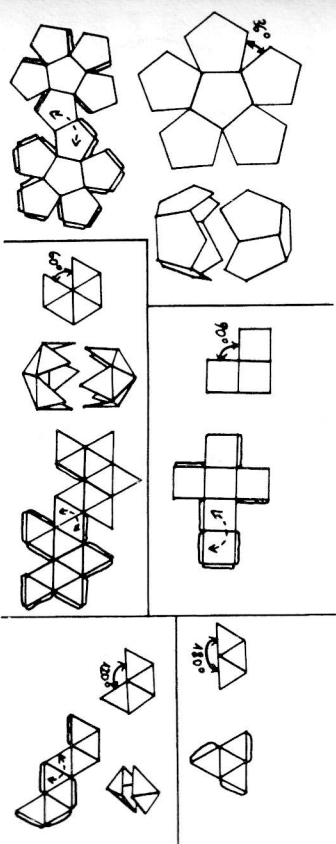

Fig. 21.

construction plans of the Platonic solids (Figure 21), pictures of all Archimedean solids (for prism and anti-prism only one example each) (Figure 22), an overhead projector, transparencies of the students' working-sheets, a blackboard, and, last but not least, balls with surface structures of various kinds, models of (Archimedean) solids, a globe, an orange, and an egg (Figure 23).

Now to the sequence of the lessons:

#### First Lesson

1. Balls with surface structures of various kinds, Platonic solids, pyramids, an orange, an egg, and a picture of a rugby ball. The purpose of the football is analyzed. By rehearsing games with balls of alternative properties students decide that the ball should be highly symmetric (homogeneous), without protrusions or indentations, elastic, light, and robust; briefly: a leather sphere. Trying to curve plane paper to a sphere and the peel of the orange or the shell



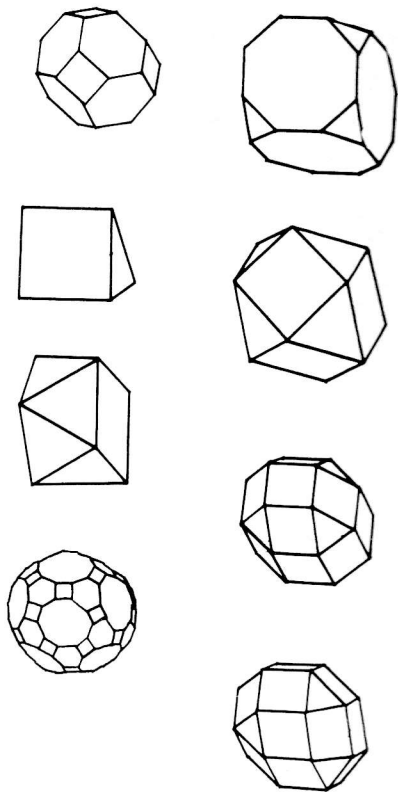

Fig. 22. Pictures of some Archimedean solids.

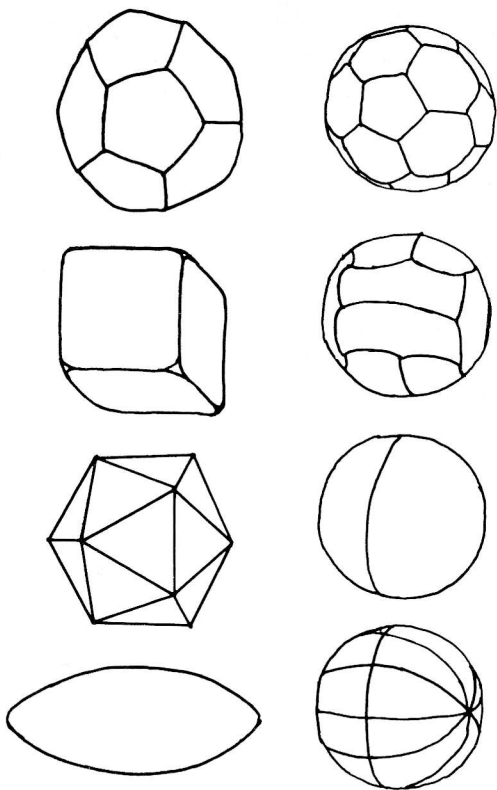

Fig. 23. Some variants of the form of the football.

of the egg to planes the students recognize that a football cannot be made of *one* flat piece of leather, but only of several smaller pieces sewn together. Criteria are developed. For the sake of hard wear: straight, short seams, and not too many of them; at each vertex only three seams; furthermore pieces of leather which are convex (hence polygonal) and not too big (because of the inflation pressure) and, at the same time, not too small (in order to keep the number of seams small). For the sake of symmetry: regular polygons and one kind of arrangement of polygons for all vertices. For the sake of roundness:

small polygons and consequently all of (nearly) equal size. The form of the truncated icosahedron (we did not mention that name) seems to fulfil these criteria well. Is it the best form possible?

2. Plane tessellations, starting from floors, ornaments, walls, etc.; definition, examples, counterexamples. The students lay and draw tessellations which fulfil certain conditions. For some vertices the equivalence of their stars is shown by superimposing two transparencies with the same tessellation on the projector and sliding and turning them suitably with respect to each other.

We start with *plane* tessellations, because they can be seen through and constructed more easily, and, even more important, the construction of the solids will be started from (incomplete) plane tessellations.

### Second Lesson

No. 2 continued.

3. From now on we consider only tessellations with the following properties: the tiles are polygons (with all angles different from  $180^\circ$ ); the pattern is repeated in at least two (linearly independent) directions (i.e., the symmetry group of the tessellation contains at least two translations on different straight lines); a point, being a vertex of one polygon, is a vertex of any polygon meeting it. Examples and counterexamples are presented and discussed.

When the students construct tessellations, they start with one vertex, fill up its neighbourhood with polygons (the star of this vertex; we call it Eckenkranz, i.e., the wreath of the vertex). In order to make sure that the tiling can be continued all over the plane with the projected pattern they have to lay one more full ring around that star already constructed. They learn by counterexamples that constructing only the star of one vertex is not sufficient, e.g., there is no tessellation with the star  $(3\ 4\ 3\ 12)$  at each vertex, though one vertex can have this star (Figure 24).

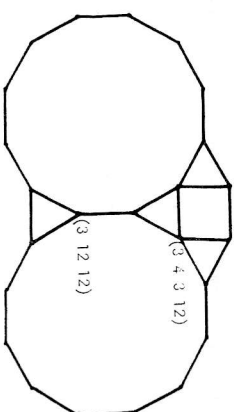

Fig. 24

*Third Lesson*

No. 3 continued. Find out and verify that any triangle and any quadrilateral generates a tessellation in the above sense. Students tessellate with a non-convex quadrilateral. Why does the procedure not work for  $n$ -gons with  $n > 4$  in general? (The angles turn out to be important.)

4. Proof of the fact that the sum of the interior angles of an  $n$ -gon is  $(n-2) \cdot 180^\circ$  and that the interior angle of the regular  $n$ -gon is  $(n-2) \cdot 180^\circ/n$ . Students make out the list of the angles of the  $n$ -gons for  $n = 3, 4, \dots, 12$  and some larger  $n$  (up to  $n = 1000$ ). They see that the angle tends to  $180^\circ$  as  $n$  tends to infinity. The list (up to 12) will be used in the following lessons.

*Fourth Lesson*

5. Symbolize the stars with cyclic  $n$ -tuples, e.g.,  $\begin{matrix} 3 & 3 \\ 4 & 3 \end{matrix}$  for (3 3 4 3 4). A

tessellation is Archimedean, if and only if its vertices all have the same star. Find all Archimedean tessellations! They can be divided into classes according to the number of polygons in a star. If there are 6 polygons, then these must be 6 triangles. For the remaining cases 5, 4, and 3, the students form groups, each working on one case. It is not so important that the students find all the possibilities on their own. They should understand that there is a finite number and that there are ways to find these possibilities, which are accessible to them. So we helped a lot, especially the groups with case 3 by demonstrating the proposition: if a star has 3 (and not more) polygons and one has an odd number of vertices, then the two others must have an equal number.

*Fifth Lesson*

No. 5 continued. The groups report.

6. A plane star cannot consist of 3 regular pentagons (cf. Figure 21), because they leave a gap (of  $36^\circ$ ). Fold them at the two separating edges and turn the two free pentagons upwards until they meet. Thus a star has been formed which is not planar. Students visualize that a continuation with more pentagons leads to a spherical form. They are given the construction plan (cf. Figure 21): make 2 bowls, each with one pentagon as the base and the wall consisting of 5 pentagons, and fit them together. The students make sure that all the vertices have the same star, transfer the concept of Archimedean tessellation to solids, and apply the same symbolism, here  $\begin{matrix} 5 & 5 \\ 5 & 5 \end{matrix}$  for (5 5 5).

*Sixth Lesson*

7. Find all the Archimedean solids which use only one kind of polygon. Could one take hexagons or  $n$ -gons with even more vertices? No, because each star of a solid must have (at least) three polygons, and the polygons arranged around a vertex in the plane must leave a gap. So take 3 triangles or 3 quadrilaterals for one star. The corresponding 'bowls' are the complete solid (3 3 3), or they leave only one face for the top (4 4 4). There are two more possibilities: 4 or 5 triangles for one star. Make two 4- (or 5-) sided pyramids, stick them together, and obtain (3 3 3 3) (or (3 3 3 3 3)). Checking the stars the students realize that the solid they call (3 3 3 3) also has stars (3 3 3 3), hence is not Archimedean (one can recognize the shortcoming already by the asymmetric form). They obtain the right form by extending one pyramid with triangles or by constructing according to the plan in Figure 21. These 5 solids constitute a special class of Archimedean solids, called Platonic solids (there are also plane Platonic tessellations, but their being special is not so important); their customary names are given but the students need not use them.

*Seventh Lesson*

8. Find a relationship between the approximation to the sphere and the gaps in the plane: the smaller the gap, the better the sphere, as the edges are less sharp. How can the gap be diminished? Allow different kinds of regular polygons. But still the sum of the angles at one vertex must be less than  $360^\circ$ , and, of course, all the stars must be the same. The students look for collections of polygons which, arranged around a vertex in the plane, leave a gap as small as possible. By teamwork, some of the suggestions are partially or completely realized as Archimedean solids. The students learn that there is no Archimedean solid (3 10 12), which would have a very small gap, namely  $6^\circ$ . For that they verify that the proposition about plane tessellations given in the fourth lesson also holds for solids. Furthermore, the example of the prism (4 4 1000) shows that a small gap does not guarantee a good sphere.

*Eighth Lesson*

9. How can all Archimedean solids be found? The same method as with plane tessellations: the case of 6 polygons in a star cannot occur, and the cases 5, 4, and 3 can be investigated as before. The students do not actually make these investigations. They are given pictures of all the Archimedean solids, compare

them with each other using the criteria from the first lesson, and decide that (5 6 6) is the best football.

10. Discussion about how to make (3 8 8) out of a *massive* cube. The new edges are not half as long as the old ones. Are there other Archimedean solids which can be made from the cube? Where does (5 6 6) originate from? Students name objects of everyday life which have the form of an Archimedean solid:

- die (cube (4 4 4));
- ball for babies which must not roll too well (dodecahedron (5 5 5));
- swimming pool (prism (4 4  $n$ )), however: the  $n$ -gons need not be regular and the 4-gons can be non-square rectangles;
- truncated die for better rolling (truncated cube (3 8 8)), however: the edges need not all have the same length;
- beverage packaging (tetrahedron (3 3 3)): with the net of the tetrahedron the plane, and even a parallel strip can be tessellated. In practice the third version of Figure 25 is taken which yields only one seam in each vertex and therefore tight packaging (for details cf. [19]), again: the edges need not have one length.

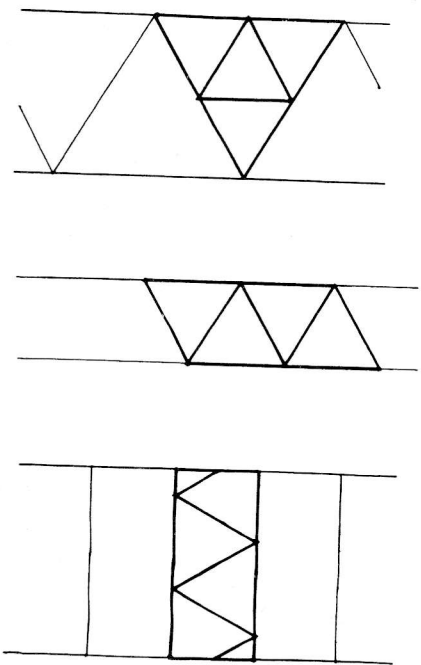

Fig. 25.

11. Questions for the test (taken later):

- (a) Describe the surface of the leather football used nowadays, and give arguments.
- (b) Name objects from the world around you which are Archimedean solids. Denote them with symbols. Find reasons for their forms.
- (c) Why is (5 6 6) a better football than (3 8 8) or (3 3 3 3 3)?

- (d) Complete the list. (List with sums of angles for polygons and angles of regular polygons, with some omissions.)
- (e) Draw (3 6 3 6).
- (f) Give a customary name for (4 4 4).
- (g) Why is this solid not Archimedean? (Drawing of a 4-sided pyramid.)
- (h) Decide, if this is Archimedean or not. If you think 'yes', give the symbol. If you think 'no', explain why (Drawings of (3 3 3 4 4), of a tessellation with non-rectangular rhomboids, and of a tessellation with varying stars.)
- (i) How can you decide without drawing that (3 12 12) is plane and (3 10 10) solid?
- (j) (3 4 6  $x$ ) is a plane Archimedean tessellation. Calculate  $x$ .
- (k) What gap is left, when a rectangular triangle, hexagon and nonagon are arranged around a vertex in the plane?
- (l) Why is there no plane or solid Archimedean tessellation of (3 8 10)?

Question (l) was not included in the test. The discussions in (a) and in (c) were often superficial and not detailed. In (b) some students denoted the cube with (4 4 4 4). In (e) some students drew tessellations with stars of (3 6 3 6) and (3 3 6 6) or drew only a strip and no full star at all. In (f) some gave 'Platonic solid'. In (g) some thought it was Archimedean. In (h) many thought the tessellation with rhomboids was Archimedean.

#### Pädagogische Hochschule Neuss

#### REFERENCES

- [1] Bauersfeld, H., 'Die Grundlegung und Vorbereitung geometrischen Denkens in der Grundschule', in Rupprecht, H. (ed.), *Erziehung zum produktiven Denken*, Herder, Freiburg, 1967.
- [2] Bauersfeld, H., Orte, M., and Steiner, H. G., (eds.), *Proceedings of the ICM-IDM Regional Conference on the Teaching of Geometry*, Schriftenreihe des IDM, 3/1974.
- [3] Bender, P., 'Umwelterschließung im Geometrieunterricht durch operative Begriffsbildung', *Der Mathematikunterricht* 24/5 (1978), 25-87.
- [4] Bender, P. and Schreiber, A., *Operative Genese der Geometrie*, Monograph (to appear).
- [5] Bishop, A. J., 'Visual Mathematics', in [2], (1974), 165-189.
- [6] Bruner, J. S., *The Process of Education*, Harvard Univ. Press, Cambridge, Mass., U.S.A., 1960.
- [7] Dingler, H., *Die Grundlagen der Geometrie*, Ferdinand Enke, Stuttgart, 1933.
- [8] Dingler, H., *Die Methode der Physik*, Ernst Reinhardt, München, 1938.
- [9] Eggard, J. C., 'Some Ideas in Geometry That Can be Taught from K-6', *Educational Studies in Mathematics* 2 (1970), 478-495.
- [10] Fletcher, T. J., 'The Teaching of Geometry, Present Problems and Future Aims', *Educational Studies in Mathematics* 3 (1971), 395-412.